



LaBella

Powered by partnership.

VILLAGE OF TANNERSVILLE

DOWNTOWN REVITALIZATION
FUND



AGENDA

- Timeline
- Application Process
- Project Development
- Process if Awarded
- Questions

TIMELINE

Village of Tannersville: DRI Downtown Revitalization Fund Administration Services

	Jan	Feb	Mar	Apr	May	June	July	Aug	Sept	Oct	Nov	Dec
2024	Kick off with Municipality	Solicitation to businesses and properties			Evaluation and selection process				Prepare bidding documents and bid to contractors/vendors		Construction/purchase equipment phase	
								Environmental and SHPO Review				
	Jan	Feb	Mar	Apr	May	June	July	Aug	Sept	Oct	Nov	Dec
2025	Construction/purchase equipment phase						Project close out and distribution requests					
										Monitoring reporting		

Total Timeline: 22 months

DRI PROJECT AREA



ELIGIBLE BUILDING IMPROVEMENTS

- Exterior Improvements
 - Facade, Roof, Windows
 - Signs, Awnings
- Interior Improvements
 - Systems – Electrical, Plumbing, HVAC
 - Flooring, Walls, Ceiling
- Commercial, Residential



INELIGIBLE USE OF FUNDS

- Additions / New Builds
- Building Demolitions
- Site Work –
Landscaping, Parking
Lots
- Residential only patios



REIMBURSEMENT PROGRAM

- \$50,000 \$100,000– commercial only
- Additional \$25,000 per residential unit up to \$150,000 total grant award
- Program reimburses 60% of total project costs





1 PROPOSED EAST ELEVATION
 Scale: 3/8" = 1'-0"
 GENERAL NOTE: COORDINATE COLOR SELECTION OF ALL NEW MATERIAL FINISHES WITH SELECTED COLOR PALETTE AND OWNER.

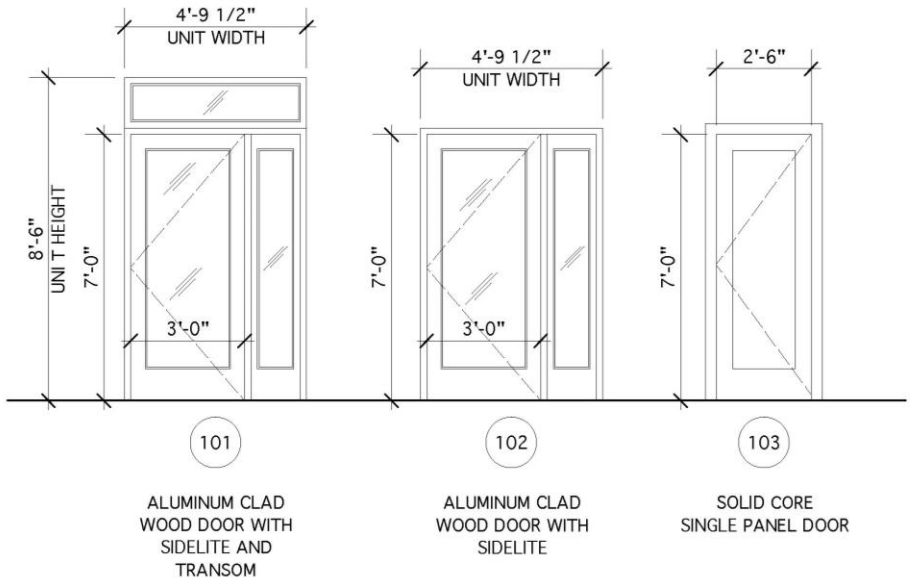

ELIGIBLE PROJECT DELIVERY COSTS "SOFT COSTS"

- Design Services
 - Architectural
 - Engineering
- Environmental Testing
- Soft Costs: 18% maximum of the grant awarded funds

Category	Description	Points
Readiness	Projects that provide proof of overall feasibility and readiness such as proof of ownership, documentation that 100% of the financing for the project is in place, reasonable construction timeline.	20
Physical Impact	Projects that are visually prominent downtown, have historic value, are in danger of being lost, bring existing properties into compliance with design guidelines, that are transformative beyond normal maintenance.	20
Economic Impact	Projects leveraging grant funds with private investment that with the assistance of grant funds, will reduce blight and vacancies, contribute to the economic recovery of the target area, or realize a stabilization or expansion of downtown tax base, businesses and/or jobs.	20
Quality of Life	Projects include renovation of upper-story residential units, energy efficiency or accessibility improvements, solar installations and similar activities that achieve Passive House or similar standards.	20
DRI Priorities	Projects that advance goals and priorities of the DRI Investment Strategy.	20
Total		100



**Homes and
Community Renewal**

STATE REQUIREMENTS

- Two Bids
- Environmental
 - SHPO
 - Zoning
 - Ground Contamination
 - Lead/Radon/Asbestos
- M/WBE/SDVOB
- Asset Maintenance – 5 years
 - Maintain Improvements
 - Vacant Residential Units -
Maintain Affordability

PROJECT DEVELOPMENT





2017.07.19

CHURCH BUILDING

96 Main Street
Camden, NY 13316
Owner: Mark Fox

SCOPE OF WORK



BID PROPOSAL FORM:

Issue Date: Wednesday, July 19, 2017
Due Date: Wednesday, August 2, 2017 By: 3 pm

CHURCH BUILDING AT 96 MAIN STREET

Bids may be submitted by fax, email or in person, and a hard copy mailed and received by the due date. Per the NYMS program, bids must be submitted to: **Ed Flynn at Labella Associates:** 300 State Street, Suite 201 Rochester, NY 14614 (fax, XXX.XXX.XXXX). Construction is for summer/fall 2017 with completion by December of 2017.

Labella Associates will provide half size drawing sets. For full size drawing sets, contact: **Kimberly Kraft at in.site:architecture** (phone, 585.237.2614).

The undersigned proposes to provide all labor, material, allowances, transportation and other expenses required for the Church Building at 96 Main Street, Camden NY, in accordance with the Contract Documents dated July 06, 2017 and any Addenda issued prior to the Bid Due date, prepared by In Site: Architecture, for the Base Bid Sum of:

(\$ _____)

Receipt of Addenda Numbered _____ is acknowledged.

Scope of work and all owner supplied items are described and annotated in the associated drawings. The following cost breakdown is required:

Scope of Work:	
1. General Conditions	\$ _____
2. Window Replacement	
1. Removals	\$ _____
2. Repointing work as necessary	\$ _____
3. Interior finish and trim work as necessary	\$ _____
4. New infill panels at dropped ceiling locations	\$ _____
5. New aluminum clad wood windows - break down cost into groups as follows:	
1. Window Types A and B	\$ _____
2. Window Type C	\$ _____
3. Window Types D,E, F, and G	\$ _____
3. Entry Door 101	
1. Demolition and removals	\$ _____
2. Repointing work as necessary	\$ _____
3. Interior finish and trim work as necessary	\$ _____
4. New aluminum clad wood door and hardware	\$ _____
4. Entry Door 102	
1. Demolition and removals	\$ _____
2. Repointing work as necessary	\$ _____

06.2017

ed on the drawings.
drawings.
head.
ement work areas.
ith Owner.

ed on the drawings.
awings.
ilation.

drawings.

STEP 1: SCOPE DEVELOPMENT & ENVIRONMENTAL

- Prepare Work-Write Up / Scope
- May Require Design Assistance
- Environmental Assessment
- Environmental testing if necessary
- Lead Testing if needed
- Historic Preservation
- Zoning/Code Compliance

110-120 North Main Street
Elmira, NY 14901

Project Manual

Client:

James Capriotti

Mail Bid Submissions to:

City of Elmira
C/O: Ed Flynn
LaBella Associates P.C.
300 State Street, Suite 201
Rochester, NY 14614

Project Walkthrough:

March XXth, 2019

Bids Due:

Before 4pm on the 5th day of April 2019



Architect:
Johnson-Schmidt Architect P.C.
15 E. Market St.
Corning, NY 14830
607-937-1946

March 20, 2019

STEP 2: PROJECT BIDDING

- Village sends Work Write-up out for Bids
 - Applicant selects contractor
 - At least 2 bids
 - Minority & Women, SDVOB Businesses solicitation
- Review Bids/Select Contractor(s)
 - Meet Bid specs
 - Reimbursement based on lowest bid

VICTOR LOCAL DEVELOPMENT CORPORATION
BUILDING IMPROVEMENT PROGRAM
INSPECTION REPORT

OWNER(S): _____

ADDRESS: _____

DATE OF (FINAL) (PROGRESS) INSPECTION: _____

CONTRACTOR: _____

Item	Amount Requested	Amount Recommended	Comments
TOTAL			

OTHER COMMENTS: _____

This is to notify the Victor LDC that the property improvements identified have been made under the Building Improvement Program and have been performed to my satisfaction.

PROGRAM INSPECTOR: _____ DATE: _____

STEP 3: REIMBURSEMENT & CLOSEOUT

- Reimbursement Program
 - Pay First: Entire Project
 - Reimbursement at end of project
- Submit Paid Invoices and Cancelled Checks
- Inspection
- Environmental Clearance
- Residential – Proof of Rent Level
- Reimbursement – 4 weeks

Village of Tannersville
Downtown Revitalization Fund Program

APPLICATION

DUE: March 29th, 4:00 P.M.

Directions: Please complete all fields in the application below. Gather and provide all required supporting documentation and include those with the application form. Please complete a separate application form for each property you are requesting funding for. If you require additional space for any responses, please attach an additional sheet and identify the response according to the application question letters and numbers.

Completed applications can be dropped off at Village Hall during business hours or e-mailed to Devin Bulger at dbulger@labellapc.com.

A. Property Owner Information

Name of owner:

Mailing address:

Telephone number:

days: evenings:

Fax:

E-mail:

B. Business and Property Information

1. Address of property:

2. Name of business(es):

INFORMATION WE NEED FROM YOU

- Application
- Project Documentation
 - Renderings/Sketches of work
 - Proof of Financing
 - Verification of funds or loan letter
 - Current cost estimates

QUESTIONS?

